



US00D815227S

(12) **United States Design Patent**
Ma

(10) **Patent No.:** **US D815,227 S**

(45) **Date of Patent:** **** Apr. 10, 2018**

- (54) **FOOT-DECK BASED VEHICLE**
- (71) Applicant: **Koofy Development Limited**, West Avenue (CN)
- (72) Inventor: **Ondy Song Qi Ma**, Hong Kong (CN)
- (73) Assignee: **KOOFY INNOVATION LIMITED**, Hong Kong (CN)
- (**) Term: **15 Years**

D797,875 S *	9/2017	Ma	D21/760
9,802,109 B2 *	10/2017	Doerksen	A63C 17/12
D802,693 S *	11/2017	Lu	D21/765
2007/0254789 A1 *	11/2007	Odien	A63B 21/0058
				482/146
2010/0330876 A1 *	12/2010	Carlson	A63H 17/26
				446/462
2015/0107922 A1 *	4/2015	Bigler	A63C 17/12
				180/181
2016/0121198 A1 *	5/2016	Doerksen	A63C 17/01
				701/22

* cited by examiner

- (21) Appl. No.: **29/586,303**
- (22) Filed: **Dec. 2, 2016**
- (51) **LOC (11) Cl.** **21-02**
- (52) **U.S. Cl.**
- USPC **D21/765**
- (58) **Field of Classification Search**
- USPC D21/419, 421, 423, 426, 662, 760, 765, D21/766, 769, 771, 776, 77; D12/1; 280/7.14, 11.115, 11.19, 11.27, 87.042, 280/610; 434/247, 253, 258; D34/23, D34/28; 180/181; 446/462; 482/92, 482/146; 701/22
- CPC A63C 17/01; A63C 17/011; A63C 17/012; A63C 17/014; A63C 17/015; A63C 17/02; A63C 17/26; A63C 5/003; B60Q 1/326; B62K 3/001
- See application file for complete search history.

Primary Examiner — Vy Koenig
Assistant Examiner — Keith Wilson
 (74) *Attorney, Agent, or Firm* — Millman IP Inc.

(57) **CLAIM**

The ornamental design for a foot-deck based vehicle, as shown and described.

DESCRIPTION

FIG. 1 is a perspective view from above, to the front and to one side of the new design for a foot-deck based vehicle; FIG. 2 is a perspective view from below, to the front and to one side thereof; FIG. 3 is a front view thereof; FIG. 4 is a left side view thereof; FIG. 5 is a top view thereof; FIG. 6 is a right side view thereof; FIG. 7 is a rear side view thereof; and, FIG. 8 is a bottom view thereof.

The portions of the foot-deck based vehicle depicted in broken lines have been shown for the purpose of illustrating portions of the foot-deck based vehicle that form no part of the claimed design.

(56) **References Cited**
U.S. PATENT DOCUMENTS

D704,786 S *	5/2014	Tang	D21/765
D746,928 S *	1/2016	Doerksen	D21/765
D768,252 S *	10/2016	Bigler	D21/760
D769,997 S *	10/2016	Doerksen	D21/765

1 Claim, 6 Drawing Sheets

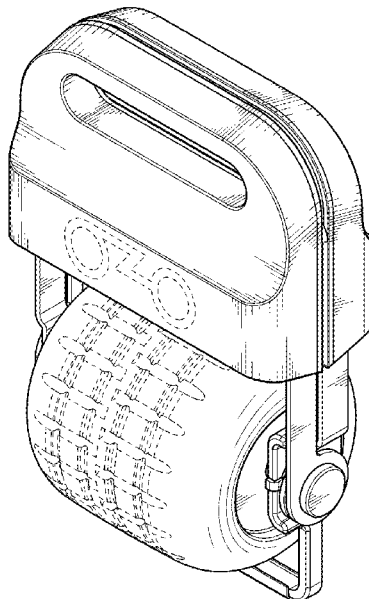

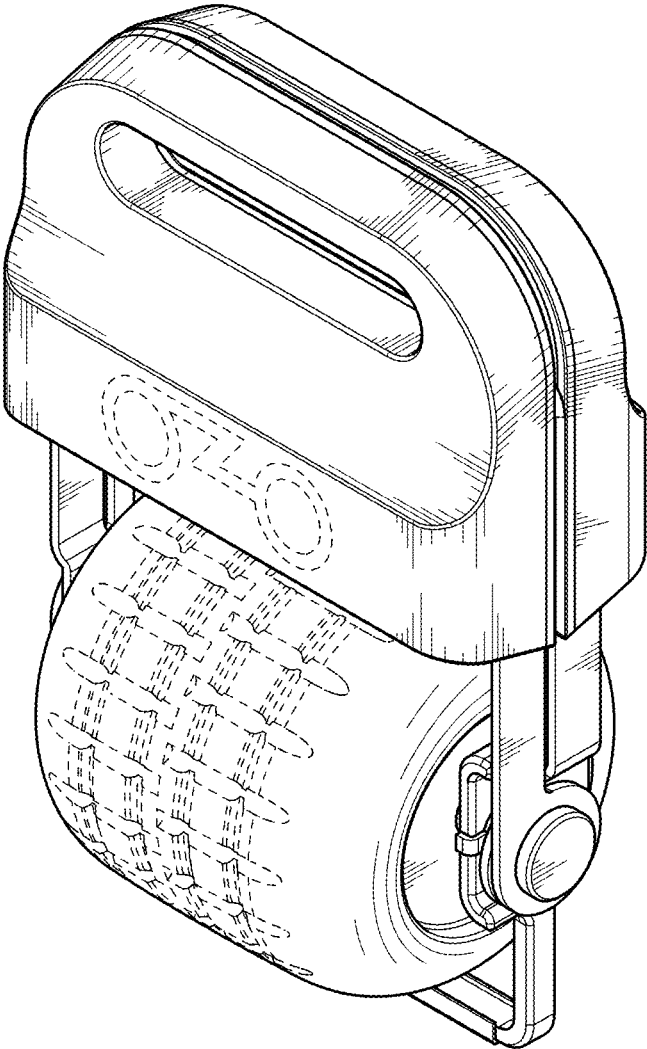

FIG. 1

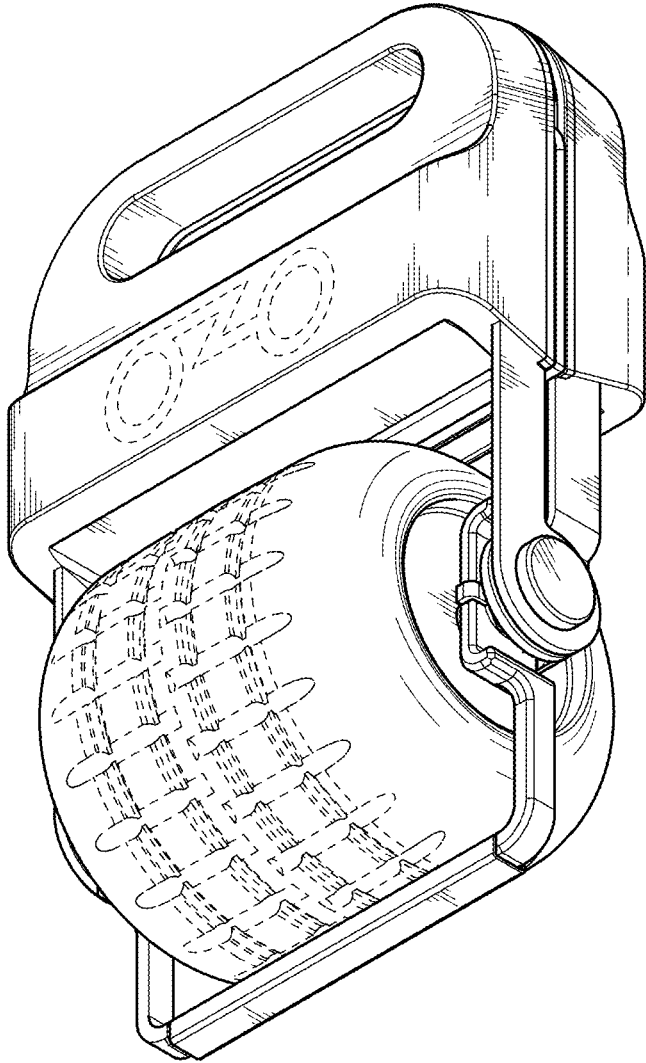

FIG. 2

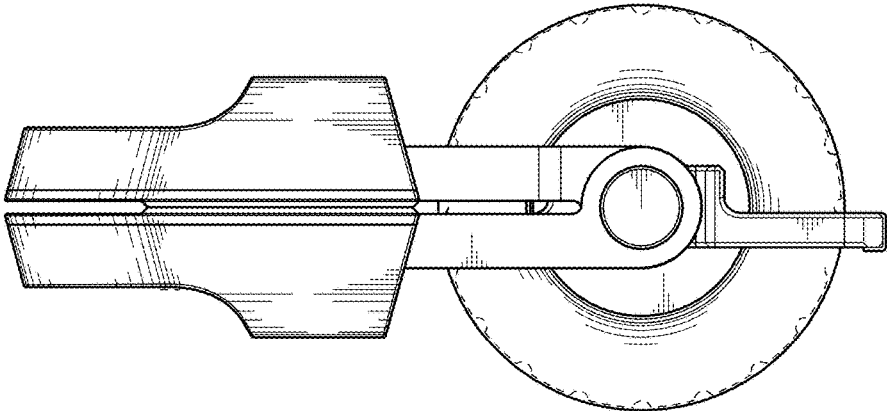

FIG. 4

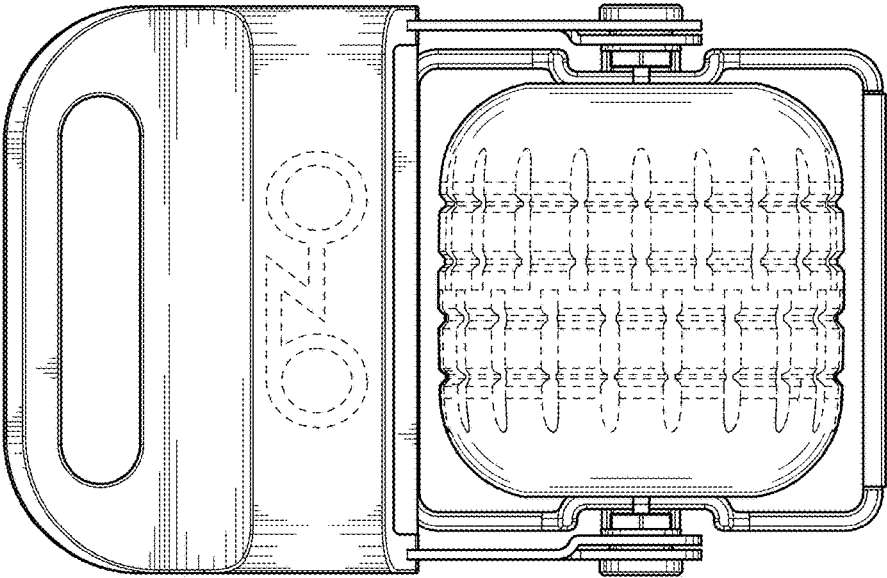

FIG. 3

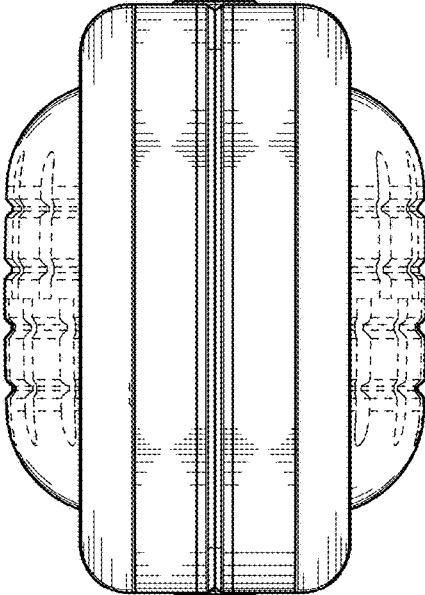

FIG. 5

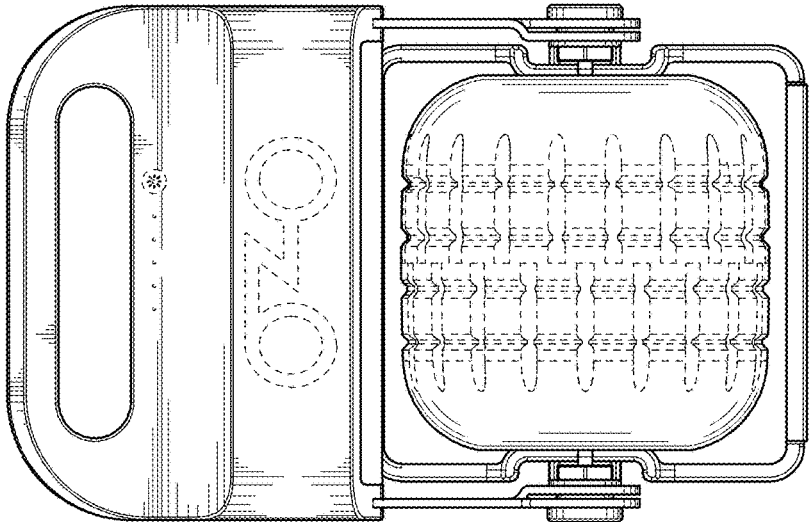

FIG. 7

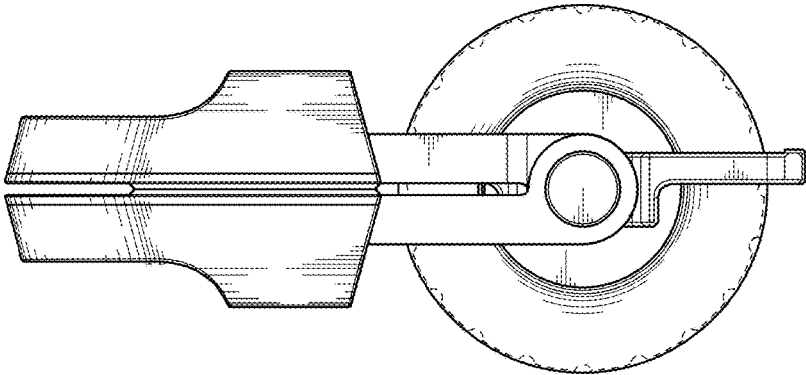

FIG. 6

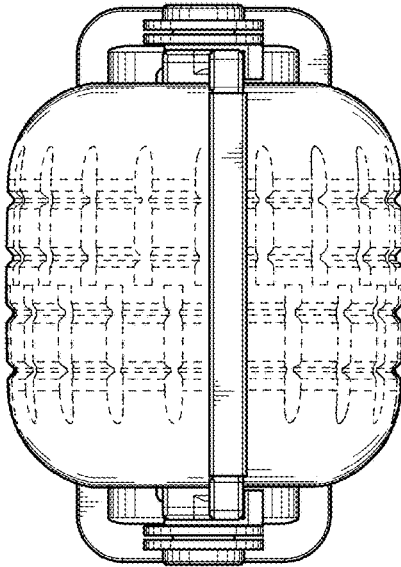

FIG. 8